

# MOTOR LOAD CONTROL MODEL PMP-1701

The Model PMP-1701 monitors the power going to a motor.

By sensing power (Volts x Amps x Power Factor) rather than just amps, there is a lot of sensitivity. For loss of load detection, this means a 10X improvement in performance.



## FEATURES

### Two Adjustable Set Points:

High Trip — When the load is above the Set Point, a relay will trip.

Low Trip — When the load is below the low Set Point, a relay will trip.

**Digital Load Display** — Large .6" 3 digit LED shows either % load or Horsepower.

**Set Read Switches** — When pressed, shows on the digital display where the Set Points are. Makes set-up and adjustment easy.

**Adjustable Start Up Timer** — Avoids false trips during motor start up. 1 to 12 seconds.

**Adjustable Trip Delay Timers** — Filter out nuisance trips. Relay won't trip until the selected time delay is exceeded. High trip delay .5-5 seconds adjustable, low trip delay 1-30 seconds adjustable.

**Reset** — The relays latch when tripped. Each relay can be reset 3 ways.

- Remotely — With switch, relay or programmable controller.
- Manually — With switch on control.
- Automatic — With a jumper.

### Relay Outputs

- 2 Form C Relays
- Up to 3 Amps at 120 VAC
- or 1/8 HP at 240 VAC

### Analog Output

4-20mA Analog Output proportional to motor HP, for external meters, chart recorders or computers.

## **MOUNTING**

The PMP-1701 is housed in a NEMA 4, 4x polycarbonate enclosure 6-7/8" x 6-7/8" x 3" (175mm x 175mm x 75mm). It can be located inside a control cabinet or on a cabinet door. The mounting holes are located below the plastic cover screws. Mounting holes pattern 6-3/16" square (157mm).

Remove the faceplate (3 phillips head screws) to get at the Terminal Strip.

The rear conduit knockouts can be used or holes can be made with Greenlee hole punch. To avoid damage, the electronics can be removed by unscrewing the 3 long 1/4" hex standoffs. When requested, the PMP-1701 can be supplied with hinges on the clear cover. With hinges, the enclosure is not rated NEMA 4.

## **CAPACITY**

The PMP-1701 senses the power input to a motor. The capacity of the PMP-1701 depends on how you hook up the current and voltage samples. The tables on pages 3 and 4 show capacities for various hook-ups.

After the hook-up is complete, you can adjust the digital load meter to read:

**EITHER**

**Your Motor Horsepower Directly OR % of Your Motor Full Load**

## **VOLTAGE**

120 Volts AC is taken from two of the phases. If the motor starter already has a 120 Volt control transformer with 10VA of free capacity, it can be used. Otherwise, install a separate transformer. It is OK if the secondary is grounded. **BE SURE TO NOTE WHICH TWO PHASES SUPPLY THE TRANSFORMER**

In a 120/208V three phase system, the 120V **MUST** come from a transformer connected to two of the phases. The 120V phase to ground voltage cannot be used.

## **CURRENT**

The current signal is taken from the **REMAINING** phase. This current sample passes through the external toroid. With a jumper between Terminals 3 and 4, the capacity is 5 HP (460 Volts). Without the jumper, capacity is 30 HP (460 Volts).

For larger motors, an external current transformer is used together with the Toroid.

See Pages 3 and 4 for **CAPACITY** and **CT Hook-up**.

It is **VERY IMPORTANT** that the current signal comes from the phase that **IS NOT** supplying the 120V control transformer. Be extra careful when the machine has reversing starters or multi-speed windings. If a wrong phase is used the control will either:

- Work backwards
- Have reduced sensitivity

**If You Are Using A Variable Frequency Drive, Use A Different Control.  
Call LOAD CONTROLS, INC. For Help.**

# Up To 30 HP Capacity (460 Volts) - Directly Through Toroid

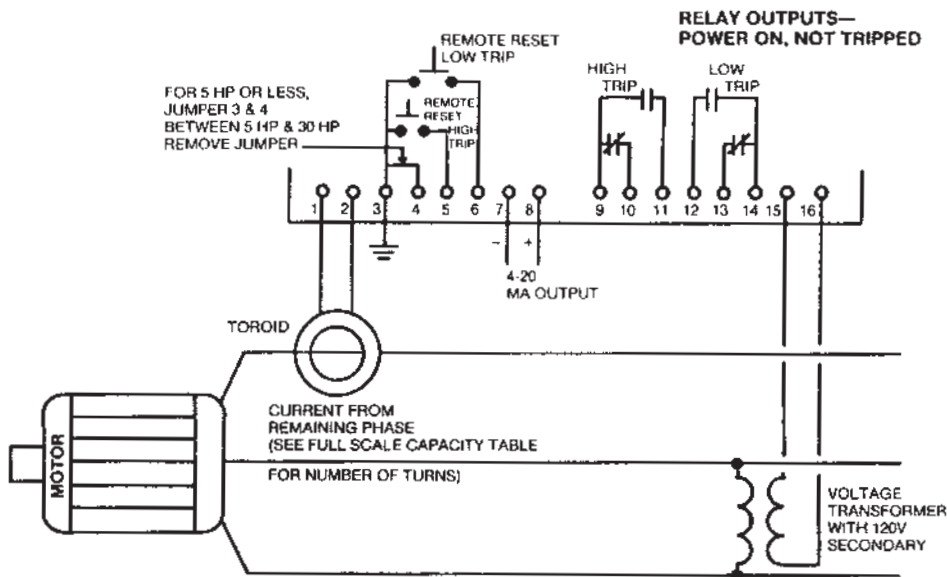

## Full Scale Capacity at 460 Volts

### Terminals 3 & 4 Jumpered

5 Turns through Toroid	1 HP
4 Turns through Toroid	1.3 HP
3 Turns through Toroid	1.8 HP
2 Turns through Toroid	2.7 HP
1 Turn through Toroid	5.3 HP

### No Jumper Terminals 3 & 4

4 Turns through Toroid	8 HP
3 Turns through Toroid	11 HP
2 Turns through Toroid	16 HP
1 Turn through Toroid	32 HP

### Multipliers

#### For Nominal Voltages Other than 460 Volts

Multiply 460V full  
scale by:

208V = .45

230V = .5

380V = .83

415V = .9

575V = 1.25

## Above 30 HP (460 Volts) Use External Current Transformer

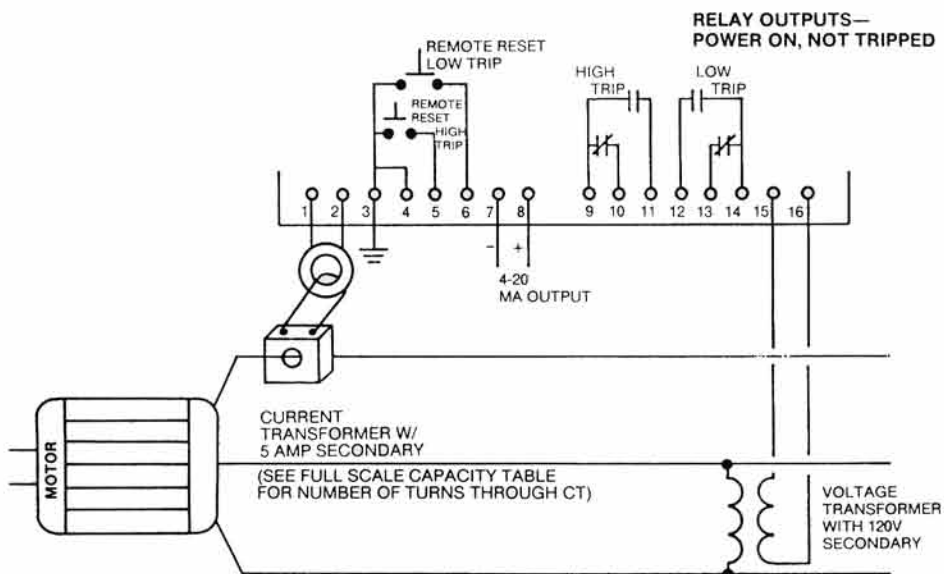

### Full Scale Capacity at 460 Volts

#### External Current Transformer Connected to Toroid Terminals 3 & 4 Jumpered

##### CT Size

150:5	4 Primary Turns through CT	40 HP
150:5	3 Primary Turns through CT	53 HP
150:5	2 Primary Turns through CT	80 HP
100:5	1 Primary Turn through CT	107 HP
150:5	1 Primary Turn through CT	160 HP
200:5	1 Primary Turn through CT	213 HP
250:5	1 Primary Turn through CT	267 HP
300:5	1 Primary Turn through CT	320 HP

#### Multipliers

##### For Nominal Voltages Other than 460 Volts

Multiply 460V full  
scale by:

208V = .45

230V = .5

380V = .83

415V = .9

575V = 1.25

The capacity (sensitivity) of the Control can be adjusted by taking more "Turns" of the leg through the Toroid. Each time the wire passes through the Toroid is a "Turn".



This is One Turn



This is Two Turns

### With External Current Transformer



Pass Secondary Of CT Through Toroid

For most loads the CT 150:5 is used and the capacity is changed by changing the number of turns. The proper number of Turns must be used to reach the desired rating.

For loads over 30 HP (460 Volts), a Current Transformer is used to reduce the primary current. The 5 Amp secondary passes through the Toroid (Jump Terminal 3 to 4 for 5 Amp capacity).



CT 150:5 with 4 Turns

## CAUTION

When current is flowing through the primary, always have a wire between the 2 brass Terminals on the CT.

If they are left open, dangerous and destructive voltages can develop.

## HOOKING UP THE RESET

Control can be reset 3 ways:

- Manually with the Reset button on the Control.
- Remotely with a remotely located Reset button or relay.
- Automatic with a jumper.

Remote Reset —

Momentarily Connect Terminal 5 to Terminal 3 for Set 1

Momentarily Connect Terminal 6 to Terminal 3 for Set 2

Automatic Reset

Jumper Terminal 5 or 6 to Terminal 3

The terminals for Reset generate a small amount of current (8-12 milliamps). To reset, you just need to connect the terminal to the circuit common (Terminal 3).

The switches or relays that you use must be suitable for low current. (Gold flashed contacts, Reed Relays, Mercury Switches).

**DON'T USE 10 AMP SWITCHES. THEY WON'T BE RELIABLE.**

**DON'T PUT 120V ON TERMINALS 1-8. IT WILL DESTROY THE CONTROL.**

## 4-20 MILLIAMP ANALOG OUTPUT

The Analog Output is directly proportional to Full Scale capacity in HP. It is always active. 500 ohm maximum connected impedance.

Terminal 8	4-20mA	Positive
Terminal 7	4-20mA	Negative

Use twisted pair or in noisy environments use shielded cable. Ground shield at other end.

Use the Full Scale capacity from the tables on pages 3 and 4 to scale external meters, chart recorders or computers.

## DIP SWITCHES

The Dip Switches are located under the front cover. Remove the 3 phillips screws.

	ON	DIP SWITCH	OFF
1	CALIBRATE		NORMAL OPERATION
3	DECIMAL X.XX		
4	DECIMAL XX.X		

## THE LOAD DISPLAY

Your Full Scale capacity depends on how you hooked up the PMP-1701. See tables on pages 3 and 4. Without adjustment, the display will read 100 when the motor load reaches the Full Scale capacity.

## ADJUSTING THE LOAD DISPLAY

The Load Display can be adjusted to read

EITHER

- Your Motor Horsepower (or Kilowatts) Directly.

OR

- % of Your Motor Full Load

## TO DISPLAY MOTOR HORSEPOWER DIRECTLY

- Check your Full Scale HP on pages 3 and 4.
- Turn on Dip Switch 1.
- With a tiny screwdriver, adjust the 12 turn pot until the display reads your Full Scale capacity. (Located in the upper left corner of the top circuit board.)
- Dip Switches 3 and 4 turn the decimal points on and off.
- Return Dip Switch 1 to OFF.
- Stick on the horsepower label.

The display will now read motor horsepower directly. If you want to display KW, multiply HP x .746.

## TO DISPLAY % OF YOUR MOTOR FULL LOAD

To display % of your motor load requires 1 calculation. It is the ratio of the PMP-1701 capacity and your motor size.

$$\text{"RATIO"} = \frac{\text{PMP-1701 Capacity}}{\text{Your Motor Size}} \times 100$$

Example:

You have a 25 HP Motor - 460 Volts. You have hooked it up with 1 turn through the Toroid. Full Scale capacity is 32 HP.

$$\text{Ratio} = 32/25 \times 100 = 128$$

The Ratio must be greater than 100. If it isn't, change your hook-up to a higher capacity.

- Turn ON Dip Switch 1. Turn off 3 and 4.
- With a tiny screwdriver adjust the 12 turn pot until the display reads your "Ratio". (Located in the upper left corner of the top circuit board.)
- Return Dip Switch 1 to OFF.

The display will now read 100% when your motor reaches its Full Load.



## ADJUSTMENTS

### Trip Set And Set Read Switches

The Trip Set pots set the power level at which the Load Control will trip.

The Set Read Switches show the trip point on the Motor Power Display. Press the Set Read Switch to read the set point on the display. Holding the switch down while adjusting the Trip Set makes set up easy.

### Start Up Timer

The Start Up Timer bypasses the Control during motor start up to avoid false trips because of current inrush. For convenience, the TIMING BEGINS WHEN THE MOTOR STARTS. The Start Up LED stays lit until the Start Up period is over.

Adjust the Start Up time with the pot on the Load Control. Clockwise for more time. The start up time should be:

- Long enough so that the load has stabilized. The Percent Load Meter should stabilize before the Start Up LED goes out.

### On-Delay Timers

To avoid nuisance trips from short overloads, On-Delay Timers bypass the Control for the selected time. The relays won't trip until the time is exceeded. If the trip condition goes away before the time is up, the timer resets to zero.

- Always start with minimum On-Delay (full counter clockwise). If you are getting trips where you don't want them, increase the On-Delay Time.

## ADJUSTMENT TIPS FOR CENTRIFUGAL PUMPS

### From Pump Curves

Use the recommended minimum and maximum flows and horsepower for your initial set points. Remember that the PMP-1701 measures power INTO the pump and the pump curves are based on motor output. So – adjust the hookup capacity down by the motor efficiency.

### Actual Operation

Low Trip – Run the pump with the OUTLET valves closed. This is the minimum flow. Set the low trip a little below this.

High Trip – Run the pump with all valves wide open. This is the maximum flow. Set the high trip a little above this.

- Make adjustments if you get nuisance trips



53 TECHNOLOGY PARK ROAD  
STURBRIDGE, MA 01566  
888-600-3247  
508-347-2606  
FAX 508-347-2064