

Load Controls

P-Series Control Installation and Troubleshooting

We highly recommend reading the Installation, Set Up and Adjustment document thoroughly before installing the P-Series Load Control. Additionally, YouTube videos are available for:

[Setting Full Scale of the PMP-25](https://www.youtube.com/watch?v=tRgjdYP9y-o&feature=youtu.be) (https://www.youtube.com/watch?v=tRgjdYP9y-o&feature=youtu.be)

[Setting the Trip Points of the PMP-25](https://www.youtube.com/watch?v=8FW9ShKf9uU&feature=youtu.be)

(https://www.youtube.com/watch?v=8FW9ShKf9uU&feature=youtu.be)

[PMP-25 Relay Wiring](https://www.youtube.com/watch?v=k_Lr-JaEA24&feature=youtu.be) (https://www.youtube.com/watch?v=k_Lr-JaEA24&feature=youtu.be)

This document covers the following topics:

- Installation and Wiring of the P-Series Control
- SetUp, Establishing Full Scale, Units to display and Trip Point(s)
- Wiring Relays
- Physical / Mounting

Installation and Wiring of the P-Series Control

Wiring Terminals - MAKE SURE terminals 1 to 8 are on the BOTTOM and 9 to 16 on the TOP. The RED plastic insert in the TOP plug (terminals 9 to 16) and RED plastic insert in the BOTTOM socket (on back of PMP-25 for wiring terminals 1 to 8) are there to BLOCK each other, NOT to match up for insertion. They can be forced together, reversing the connectors which may damage the PMP-25 if power is applied.

120V Input - Verify that the 120V connected to terminals 15 and 16 is stepped down from 2 of the 3 phases that run the motor. It is typical for the control voltage transformer in the panel to be used. This transformer will have its primary wired to 2 of the 3 phases that run the motor. The 120V CANNOT come from a lighting panel or some voltage source that is unrelated to the phases that run the motor. The PMP-25 measures HP and uses this 120V input for a Voltage sample to be multiplied with the current sampled with the Range Finder Toroid.

Range Finder Toroid - Verify that the Range Finder Toroid is on the CORRECT phase. The correct phase is the phase that is NOT used for the 120V control voltage transformer. If a current transformer is used with the Range Finder Toroid (motors larger than 50HP) it MUST be on the phase not used for the control voltage transformer.

Scale - Verify that the DIP SWITCH on the Range Finder Toroid is set to the correct position following the Installation Manual. Page 2 of the manual shows the wiring diagram and a chart

where scaling numbers for HP, % Full Load, DIP switch position and # Turns are shown for different size motors @ 460VAC.

*** The PMP-25 CANNOT work with Variable Speed Motor Drives (Use the V-series)**

4-20mA Wiring

Check Polarity - Terminal 2 is Positive and terminal 3 is Negative. This is a **SOURCING TYPE** 4-20mA output, it will power the 4-20mA loop. The open voltage for the 4-20mA current source is 12V. The maximum connected impedance is 500 ohms. The 4-20mA output is isolated and no external isolation is required. Shielded wire should be used between the output and the DCS, PLC, meter or computer system receiving the signal. Ground the shield at the readout device that is receiving the signal.

DO NOT connect a 24V power supply or a powered input to the 4-20mA output

The 4-20ma output reads Zero

- a. Have a new meter tried. In many cases a fuse is blown in the test meter.

- b. Check to see if you had connected a pull up 24V power supply to the 4-20ma loop. If so the 24V likely impacted the 4-20ma output because the internal power supply is 12V. The P-Series control has a "Sourcing" type output that needs no 4-20ma loop power. The control likely needs to come back for repair.

The 4-20ma is reading 35ma (or some really high value) when the motor is off

- a. There most likely a 24V pull up voltage connected to the loop. It has not blown up the control's 4-20ma output yet. Have it disconnected immediately and monitor this circuit for future reliability.

Motor is running but reads all Zero's or a very close to Zero.

- a. Check the Range Finder Wiring to the correct terminals. Ensure that the 4-20mA output is not wired to the Range Finder Toroid. Ensure good electrical connections. The cage clamps in the connectors can bite down on wire insulation not making a good connection.
- b. Phasing - Check to be certain the Range Finder Toroid is on the correct phase, the one NOT used for the 120V control voltage transformer? Occasionally electricians will swap phases to get the motor rotation correct during installation and the drawings will differ from the actual installation.

There needs to positively be a Control Transformer in the motor starter or cabinet that makes the 120V from 2 of the 3 phases. The 120V CANNOT come from an external source like a lighting panel it will not be related to the motor voltage. If there is not a transformer then one will be needed. A 50VA transformer can be used for 1 P-Series Control. If you are powering

more P-Series Controls, then a larger capacity transformer is needed. This transformer needs to be LINE connected and not come on and off with the motor starter.

Programming the P-Series Control, Setting Trip Points

Once the P-Series control is successfully wired up you will move to setting the control Full Scale, determining the units you will use to display Power, and establishing Trip Points. Review the videos:

- [Setting Full Scale of the PMP-25](https://www.youtube.com/watch?v=tRgjdYP9y-o&feature=youtu.be) (https://www.youtube.com/watch?v=tRgjdYP9y-o&feature=youtu.be)
- [Setting the Trip Points of the PMP-25](https://www.youtube.com/watch?v=8FW9ShKf9uU&feature=youtu.be) (https://www.youtube.com/watch?v=8FW9ShKf9uU&feature=youtu.be)

Digital Display - Full Scale Setup

Tap the FULL SCALE button to scroll the display through the Full Scale setup parameters. To change the display Full Scale setup use this procedure:

A. Choose the Full Scale Capacity or % Full Load number from the chart on page 2 of the Installation, Set Up and Adjustment manual that corresponds to the motor size. **This is the Full Range of the Control.** This is the number to be entered into the display to read either HP or %Load.

*** After pressing the FULL SCALE button the display will reset in 5 seconds back to reading the load if no further setup actions are taken. Tap the FULL SCALE button to scroll through and get back to where setup information is needed if the display resets before setup is completed.**

B. Displaying HP - Press and release the FULL SCALE button and use the UP or DOWN arrow to make the 3 digits the same as the Full Scale Capacity number. Do not be concerned with the decimal point, it will be placed into the 3-digit number in the next step. After arriving at the number press and hold the ENTER button for 5 seconds, the blinking will stop, release the button. Tap the FULL SCALE button until the decimal point moves over to the correct position. Again, press and hold the ENTER button until the blinking stops, release the button. Tap the FULL SCALE button until the HP indicator lights. Again, press and hold the ENTER button until the blinking stops, release the button. The HP indicator will now remain ON to show the display is reading in terms of HP. The display will reset back to reading the load.

C. Displaying KW – The calculation of KW is based on .746 KW per HP. Multiply the Full Scale Capacity numbers in the chart on page 2 of the installation manual by .746 for KW Full Scale Capacity numbers. Follow the procedure in step B and enter the KW number for Full Scale and light the KW indicator.

D. Displaying % Load - Press and Release the FULL SCALE button and use the UP or DOWN arrow to arrive at the Full Scale % Full Load number from the chart on page 2 of the Installation, Set Up and Adjustment manual that corresponds to the motor size. Press and hold the ENTER button for 5 seconds, the blinking will stop, then release the button. Tap the FULL SCALE button to move the decimal point fully to the right hand side and hold the ENTER button until the blinking stops. Tap the FULL SCALE button to light the % indicator and again hold the ENTER button until the blinking stops. Release the button. The display will reset back to reading the load.

Set Point Adjustments.

Tap the blue Cycle Arrow in the blue Circled Area to scroll down through for the settings made during the initial installation. Check the HIGH and LOW set points and their trip DELAY timers. Also check the START timer delay that allows the motor to get past the starting torque and settle down to the normal running power before the set points become active. Both the trip DELAY timers and the START delay timer are set in 1 second intervals from 1 to 999 seconds.

* Applications like tank unloading may require a longer trip DELAY on the LOW set point to ensure the tank is empty and the pump is not just in momentary cavitation.

* Self Priming pumps may require a longer START delay to get the pump primed before releasing the set points to become active.

To change the settings, use the UP or DOWN arrows to change the display to the new number then press and hold the ENTER button for 5 seconds until the blinking stops.

The display will reset in 5 seconds back to reading the load if no further setup actions are taken at any step. Tap the blue Cycle Arrow to move back down through the settings and get back to where the setup information is needed if the display does reset.

Where to put the Set Points?

Set Points can be entered by choosing HP points off the Flow Curve for the pump. The flow curve will show HP versus flow. The PMP-25 measures HP.

Centrifugal Pumps - If the flow curves are not available or if they were not made exactly for the fluid being pumped then the best way to find where to place the trip points is to momentarily open and close the discharge valve and record the desired max flow HP (Open Valve) and the dead head HP (Closed Valve). Place the HIGH Set Point at the desired max flow HP and the LOW Set Point just above the dead head HP.

*** Using the discharge valve will keep fluid in the pump during the momentary blocked condition. Closing the inlet valve may cause heating in the pump. Consult your pump distributor before closing the inlet valve to test the Pump Monitor behavior. Again, closing**

either valve should be done momentarily just to get readings from the display for each condition.

Positive Displacement Pumps - Use the Flow Curve for HIGH and LOW flow HP limits to be used in the PMP-25.

*** Positive Displacement Pumps behave differently than Centrifugal pumps. If the discharge valve is closed, pressure will build and the load increases. The HIGH set point is used for dead heading conditions as well as a blocked impeller. The LOW set point will detect low flow. The discharge and the inlet valves can be used to force these conditions momentarily and test Pump Monitor behavior. Consult your pump distributor before doing so to make sure it will not be harmful to that particular pump.**

Wiring Relays for Control

Output Relays

Both the HIGH and LOW output relays are shown in the Installation Set Up and Adjustment Manual on page 2. The Relays are shown with POWER ON (120V Connected) and NOT TRIPPED. The state of the relays shown is actually the energized state of the relays. **The TRIPPED condition will be the shelf state of the relays.** This is done for “Fail Safe” operation. If the 120V is lost to the control for any reason, the relays will fail to the tripped condition.

Contact Specifications:

LOW trip relay Form C 3A @ 300VAC or 1/8HP @ 240VAC HIGH trip relay Form C 3A @ 300 VAC or 1/8HP @ 240VAC

Relay Wiring

For simplicity, the state of the contacts shown in the manual will be termed the NORMAL STATE of the relays.

Typically, the N.C. (Normally Closed) contacts for the HIGH and LOW output relays are wired in series with the stop circuit to DROP OUT the motor starter after a trip condition. In the following diagram, the N.C. contacts for the LOW TRIP on terminals 10 and 11 are jumped over to the N.C. contacts for the HIGH TRIP on terminals 13 and 14 and wired in series with the STOP button. The motor starter will DROP OUT and its auxiliary contact will open if either the LOW or HIGH contacts open or the STOP button is pressed.

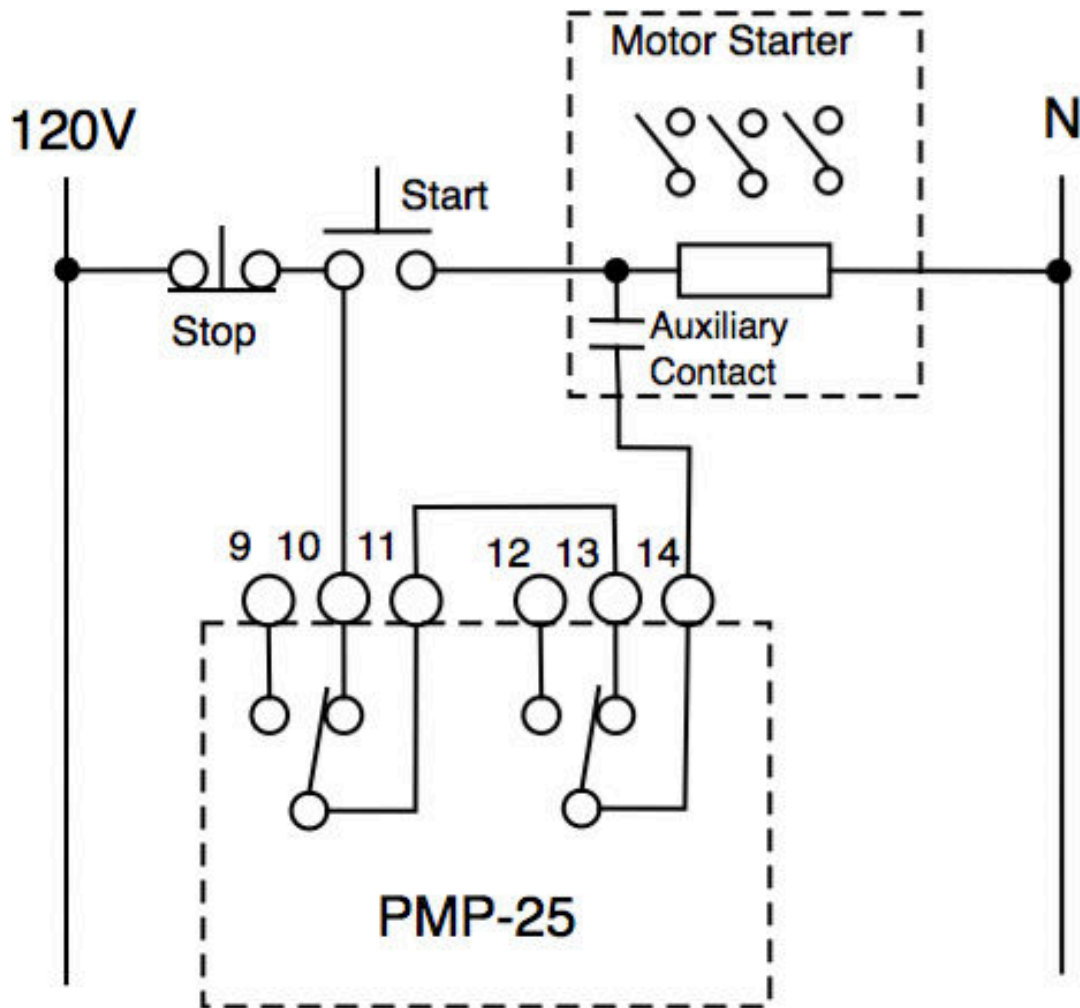

Reset - After a HIGH or LOW trip, the output contacts latch in the tripped condition and the trip indicator lights. The output contacts can only reset if the trip condition no longer exists or if the motor has been shut down and the START indicator is ON.

The PMP-25 can be Reset one of three ways:

Manual Reset - Press the RESET button on the keypad to reset the output contacts allowing a restart to be made using the Start Button in the Start / Stop circuit.

Remote Reset - A remote switch can be wired to the reset terminals 4,5 and 6. A jumper can be made across terminals 4 and 5 and then the switch wired from 4 and 5 to 6. This will reset both LOW and HIGH set points simultaneously.

Automatic Reset - Reset Terminals 4,5 and 6 can be jumped together. The output relays for LOW and HIGH will reset after the trip condition no longer exists or the motor is shut down and the START indicator is ON.

Troubleshooting Relays

The P-Series Control shows tripped, but the motor is still running. It did not shut down.

Output Relay Wiring. Check that Output Relays are in series with the motor starter STOP circuit. If a PLC is used to turn the motor ON and OFF then the logic of the output relays needs to be correct. There are normally OPEN and normally CLOSED contacts. The voltage for signaling the PLC (24VDC or 120VAC) needs to wire through the correct contacts for the logic needed. The output relays are dry contacts, there is no internal voltage. Since they operate as switches, Voltage must be wired through them.

The P-Series Control worked for a while but now the output relay does not shut down the motor.

a. Check if the Trip LED is ON? if yes, determine what size motor is it. The output relays can handle a size 2 motor starter directly. Larger starters (motors) require an auxiliary relay controlled by the P-Series Control that can handle the inductive kick of the starter coil. The holding current is not the problem it is the inductance where the “Kick” (reverse emf of the coil) causes high instantaneous voltages / currents that will adversely impact the P-Series output relay contacts. With power off an OHM meter can confirm the contacts not working any longer. A wiring procedure for an auxiliary relay is one of the youtube videos [PMP-25 Relay Wiring](https://www.youtube.com/watch?v=k_Lr-JaEA24&feature=youtu.be) (https://www.youtube.com/watch?v=k_Lr-JaEA24&feature=youtu.be)

b. Trip LED OFF? The HIGH or LOW set point may need re adjustment. What worked before may not work now as process Power requirements may have changed over time.

If a Pump Monitor LOW set point, momentarily close the discharge valve to cause a dead head (closed outlet) condition and read the value off the meter. Set the LOW setpoint just above the dead head condition. A rule of thumb for a successful LOW flow set point is a 5% difference or more between normal operation and a dead head condition. If less there may be false tripping.

The P-Series keeps False Tripping.

The set point may need to be re-adjusted to accommodate drifting Power requirements of the process over time. Set points, in most cases, can be placed away from the running power as to not cause false trips.

Physical Mounting of the P-Series Control

What is the NEMA rating for the P-Series Control?

In application the P-Series is NEMA 12 (Splash Proof) because irregularities may happen in the cut out made for mounting in the starter or cabinet door. We do not recommend pressurized water be used around the mounting gasket as seen with wash down applications such as food processing etc. The front keypad is NEMA 4 and the mounting gasket seal is as well.

Can the P-Series Control be mounted outside?

Rain is not a problem, but direct sun is a definite problem especially in warmer climates such as the Southern U.S. The ambient temperature in the control may reach levels much higher than the rated 55C. A visor should be used when in direct sunlight. This will keep the ambient temperature down.