



53 Technology Park Rd.
Sturbridge, MA 01566
888-600-3247 508-347-2064 FX

Defeat Start-Up Timer PMP-25

1) Remove PMP-25 from installed panel and use Phillips screw driver to remove 4 screws from the back corners of the enclosure to separate the enclosure halves.

2) Use Phillips to remove 3 screws holding the circuit boards together. Unplug the circuit boards

3) Use 1/4 inch nut driver to remove 3 standoffs holding the remaining circuit board into the front cover. A ribbon cable connects the keypad to this board.

BE CAREFUL not to stress this ribbon cable. Unplug this ribbon cable from the keypad. This is the board you are going to remove a component on.

4) With a pair of cutters remove Q3. Q3 is a three terminal device that is black in color. See picture below for location.

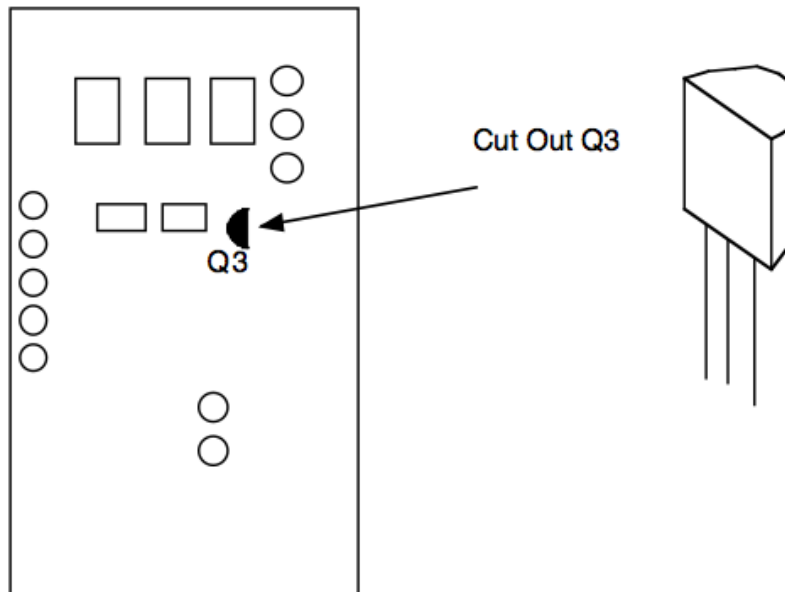

5) Reassemble circuit boards and enclosure. BE CAREFUL not to over tighten screws and standoffs , they might strip easier the second time tightened.

*** If you have any questions PLEASE CALL ***